

# AZUD

## AGL

AZUD AGL is the range of manual filters manufactured in technical plastic. It is resistant to most of the products normally used in agriculture.

The hydraulic design of the filter minimizes the head loss, saving energy and optimizing its performance.



## TECHNOLOGY

During the filtration process, the water flows inside the filtration discs where the particles are retained.

Thanks to its simple and safe structure, the maintenance labours are dramatically reduced. It is unnecessary the use of tools for the maintenance of the filter.

The optimized lock system of the thread makes the filter very resistant to the sharp changes of pressure and temperature, avoiding deformations in the set housing-thread.

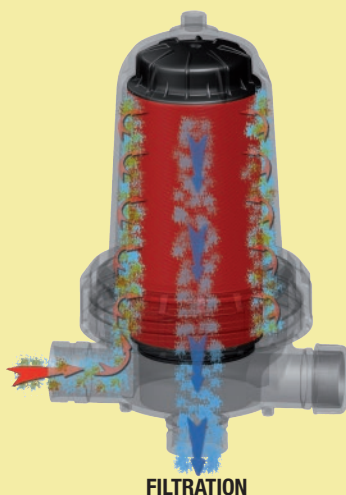

## ADVANTAGES

- ✓ **Modularity.**  
Versatility, compatibility and easy maintenance. The system permits a wide range of flow rates and configurations using a minimal number of components.
- ✓ **Maximum quality and safety in filtration.**  
Wide range of filtration grades in discs and screens.
- ✓ **The largest filtration area of its kind.**
- ✓ **Robustness.**  
Base and lid manufactured in high quality thermoplastic.
- ✓ **Easy installation, handling and maintenance.**  
No tools required for maintenance.
- ✓ **Threaded tightening nut.**  
Very resistant to variations of pressure and temperature.
- ✓ **Equipped with pressure gauges intakes.**
- ✓ **3 mouth housing with different connection possibilities.**  
BSP, NPT or grooved connection. The filter can be installed in any position.
- ✓ **Gasket set in the lid.**  
Avoiding loss or wear during maintenance.
- ✓ **The lid incorporates an auxiliary 3/4" thread.**  
It permits the installation of a depressurization valve and emptying of the filter.
- ✓ **Water and energy saving.**

# AZUD AGL

AZUD AGL 130 micron	Maximum flow		Filtering surface			
	m <sup>3</sup> /h	gpm	Discs		Screen	
			cm <sup>2</sup>	in <sup>2</sup>	cm <sup>2</sup>	in <sup>2</sup>
2"	30	132	1050	163	900	140
2"S	30	132	1660	257	1350	209
3"C	50	220	1050	163	900	140
3"	50	220	1660	257	1350	209

The flow rate given by filter, conditions the frequency of the flushings.

200 micron. (75 mesh)	130 micron. (120 mesh)	100 micron. (150 mesh)
--------------------------	---------------------------	---------------------------

## MATERIALS AZUD AGL

Housing	Polypropylene
Filtering element	Polypropylene discs Stainless steel screen
Locking threads	Polyamide reinforced with fiberglass
Sealing element	NBR

2<pH<13 • Maximum pressure 8 bar / 116 psi • Maximum temperature 60 °C / 140 °F

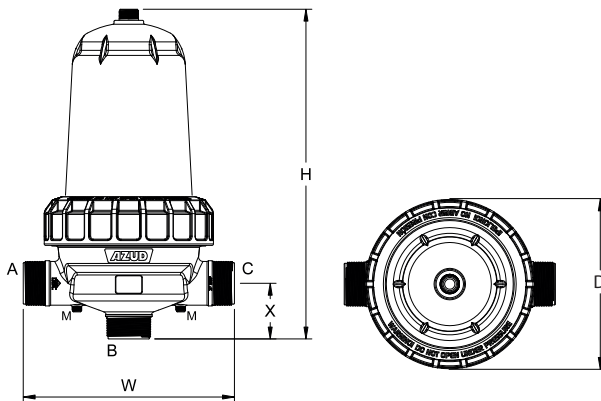

## AZUD AGL SCREEN HEAD LOSS 130 micron

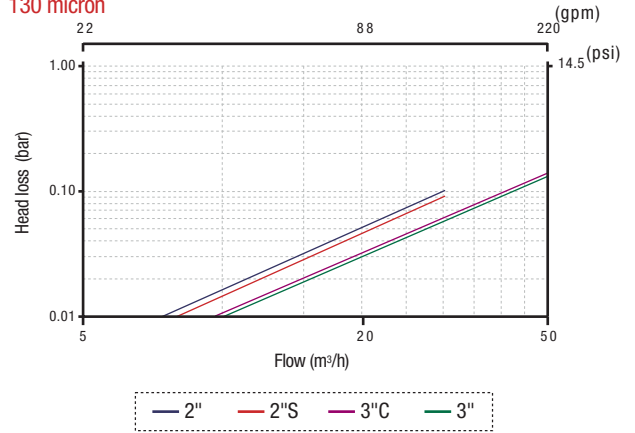

## AZUD AGL DISCS HEAD LOSS 130 micron

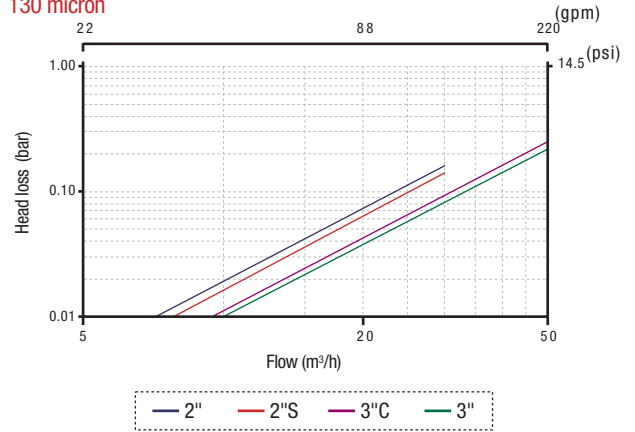

FILTER CONFIGURATION	Diameter	Model	Connection			Dimensions				Model	Weight								
			A	B	C	H		W			X		D		Empty filter Weight		Full filter Weight		
						mm	in	mm	in		mm	in	mm	in	kg	lb	kg	lb	
2"	2"	2" BSP	BSP	BSP	BSP	445	17.5	285	11.2	75	3.0	231	9.1	Disc	3.6	7.8	8.8	19.3	
		2" NPT	NPT	NPT	NPT										Screen	2.7	5.9	7.9	17.4
		2" GRV90	GROOVED	GROOVED	BSP										Disc	4.8	10.6	12.2	26.9
		2" GRV180	GROOVED	BSP	GROOVED										Screen	3.6	7.8	10.9	24.1
2"S	2"S	2"S BSP	BSP	BSP	BSP	595	23.4	285	11.2	75	3.0	231	9.1	Disc	4.8	10.6	12.2	26.9	
		2"S NPT	NPT	NPT	NPT										Screen	3.6	7.8	10.9	24.1
		2"S GRV90	GROOVED	GROOVED	BSP										Disc	4.0	8.8	9.2	20.3
		2"S GRV180	GROOVED	BSP	GROOVED										Screen	3.2	6.9	8.4	18.4
3"C	3"C	3"C BSP	BSP	BSP	BSP	495	19.5	335	13.2	110	4.3	231	9.1	Disc	4.0	8.8	9.2	20.3	
		3"C NPT	NPT	NPT	NPT										Screen	3.2	6.9	8.4	18.4
		3"C GRV90	GROOVED	GROOVED	BSP										Disc	5.3	11.7	12.6	27.7
		3"C GRV180	GROOVED	BSP	GROOVED										Screen	4.0	8.8	11.3	24.8
3"	3"	3" BSP	BSP	BSP	BSP	645	25.4	335	13.2	110	4.3	231	9.1	Disc	5.3	11.7	12.6	27.7	
		3" NPT	NPT	NPT	NPT										Screen	4.0	8.8	11.3	24.8
		3" GRV90	GROOVED	GROOVED	BSP										Disc	5.3	11.7	12.6	27.7
		3" GRV180	GROOVED	BSP	GROOVED										Screen	4.0	8.8	11.3	24.8

Connection E 3/4" BSP MT • Connection M 1/4" BSP MT